

FSP

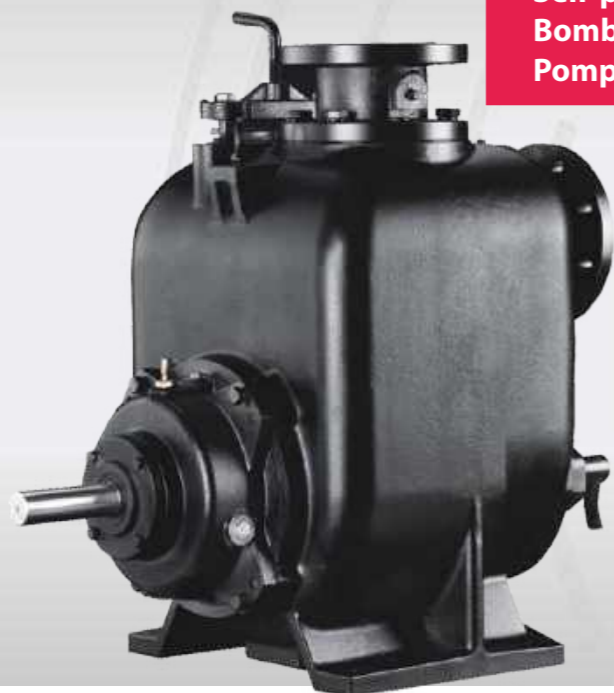

**Self-priming bare shaft pump
Bomba de eje libre autoaspirante
Pompe à arbre nu auto-amorçante**

DESCRIPTION/DESCRIPCIONES/DESCRIPTION

- ◆ Stable performance, reliable operation.
 - ◆ Rapid self-priming, high suction head.
 - ◆ Back-pull-out construction.
 - ◆ Semi-open impeller structure and non-clogging design.
 - ◆ Strong passing capacity.
 - ◆ Convenient usage.
 - ◆ The pump should be filled with water for first start.
- ◆ Rendimiento estable, operación confiable.
 - ◆ Cabezal de succión alto y autocebado rápido.
 - ◆ Construcción extraíble hacia atrás.
 - ◆ Estructura del impulsor semiabierto y diseño que no se obstruye.
 - ◆ Fuerte capacidad de pase.
 - ◆ Uso conveniente.
 - ◆ La bomba debe estar llena de agua para el primer arranque.
- ◆ Performances stables, fonctionnement fiable.
 - ◆ Auto-amorçante rapide, tête d'aspiration élevée.
 - ◆ Construction à retrait arrière.
 - ◆ Structure de turbine semi-ouverte et conception anti-colmatage.
 - ◆ Forte capacité de dépassement.
 - ◆ Utilisation pratique.
 - ◆ La pompe doit être remplie d'eau pour le premier démarrage.

APPLICATIONS/APLICACIONES/APPLICATIONS

- ◆ Suitable for the treatment project of municipal sewage and industrial sewage as well as stage treatment and concentrated treatment system of various sewages. Known as King of Self-priming Sewage pump, it is the most ideal new generation sewage product.
- ◆ Adecuado para el proyecto de tratamiento de aguas residuales municipales y aguas residuales industriales, así como el tratamiento por etapas y el sistema de tratamiento concentrado de diversas aguas residuales. Conocido como Rey de la bomba de aguas residuales autocebantes, es el producto de aguas residuales de nueva generación más ideal.
- ◆ Convient au projet de traitement des eaux usées municipales et des eaux usées industrielles ainsi qu'au traitement par étapes et au système de traitement concentré de diverses eaux usées. Connu sous le nom de Roi de la pompe à eaux usées auto-amorçante, il s'agit du produit d'égout de nouvelle génération le plus idéal.

MODEL CODE/CÓDIGO MODELO/CODE MODÈLE

For example/ Por ejemplo/ Par exemple

FSP - 4

4=Discharge size(inch)
Tamaño de descarga(inch)
Taille de décharge(inch)

FSP=Self-priming bare shaft pump
Bomba de eje libre autoaspirante
Pompe à arbre nu auto-amorçante

F FANCY

TECHNICAL DATA/DATOS TÉCNICOS/DONNÉES TECHNIQUES

MODEL MODELO MODÈLE	RPM	DN mm	Power Potencia Puissance		Rate Q/H		Max Solids Sólido máx Max solide mm	Max Suction Succión máx Asp. max m	Q=DELIVERY/CAUDAL/DÉBIT										
			kw	hp	m ³ /h	m			GPM 44	55	66	77	88	110	132	154	176	198	
			l/min 167	m ³ /h 10	12.5	15			17.5	20	25	30	35	40	45				
FSP-2	1150	50	1.1	1.5	15	4	38	5	5.1	4.7	4	3.8	3.5	-	-	-	-	-	
	1450	50	1.5	2	20	6.5	38	6.5	8.4	8.1	7.6	7.3	6.5	5.8	-	-	-	-	
	1750	50	3	4	25	9.5	38	6.5	12.6	12.2	11.8	11.3	10.8	9.5	8.5	-	-	-	
	2050	50	4	5.5	28	13.5	38	6.5	17.9	17.2	16.7	16.1	15.5	14.5	13.2	11.6	-	-	
	2350	50	7.5	10	32	18	38	6.5	-	23.2	22.5	21.8	21.2	19.9	18.6	17.2	15.3	-	
	2650	50	7.5	10	35	23	38	6.5	-	30.1	29.2	28.4	27.6	26.2	24.8	23	21.6	19.4	-
	2900	50	9.2	12.5	40	27	38	6.5	-	-	35.6	34.5	33.7	32.1	30.4	29	27	25.3	-

MODEL MODELO MODÈLE	RPM	DN mm	Power Potencia Puissance		Rate Q/H		Max Solids Sólido máx Max solide mm	Max Suction Succión máx Asp. max m	Q=DELIVERY/CAUDAL/DÉBIT									
			kw	hp	m ³ /h	m			GPM 44	88	132	176	220	264	308	352	396	441
			l/min 167	m ³ /h 10	20	30			40	50	60	70	80	90	100			
FSP-3	650	80	0.75	1	25	2	63	1.5	2.9	2.5	2	-	-	-	-	-	-	-
	750	80	1.5	2	30	3	63	1.8	3.9	3.5	3	2.3	-	-	-	-	-	-
	850	80	1.5	2	32.5	4	63	2.4	5.2	4.7	3.9	3.4	-	-	-	-	-	-
	950	80	1.5	2	40	4.5	63	3	6.4	6	5.2	4.5	3.8	-	-	-	-	-
	1050	80	3	4	42.5	5.5	63	4	7.9	7.4	6.7	5.9	5	4.3	-	-	-	-
	1150	80	4	5.5	45	7	63	4.9	9.7	9	8.3	7.4	6.5	5.6	-	-	-	-
	1250	80	4	5.5	50	8	63	5.5	11.3	10.7	10	9.1	8	7.1	6.2	-	-	-
	1350	80	5.5	7.5	52.5	10	63	5.8	-	12.6	11.9	11	10	9	7.7	-	-	-
	1450	80	5.5	7.5	55	11.5	63	6.4	-	14.7	14	12.9	12	10.8	9.6	8.3	-	-
	1550	80	7.5	10	60	12.5	63	6.4	-	16.8	16.1	15.1	14	12.5	11.7	10.4	9.1	-
	1650	80	11	15	65	14.5	63	6.7	-	19.3	18.5	17.4	16.2	15	13.6	12.3	11.1	-
	1750	80	11	15	70	16	63	6.7	-	-	20.9	19.7	18.7	17.5	16	14.5	13.2	11.8
	1850	80	15	20	72.5	18	63	7.6	-	-	23.5	22.5	21.2	20	18.4	16.9	15.3	14
	1950	80	15	20	75	20	63	7.6	-	-	26.2	25.3	24.1	22.7	21	19.6	17.9	16.4
	2050	80	18.5	25	80	22.5	63	7.6	-	-	29	28	26.8	25.3	24	22.5	20.5	18.9
2150	80	18.5	25	85	24.5	63	7.6	-	-	32.1	31	29.7	28.2	26.8	25.1	23.4	21.7	

TECHNICAL DATA/DATOS TÉCNICOS/DONNÉES TECHNIQUES

MODEL MODELO MODÈLE	RPM	DN mm	Power Potencia Puissance		Rate Q/H		Max Solids Sólido máx Max solide	Max Suction Succión máx Asp. max	Q=DELIVERY/CAUDAL/DÉBIT													
			kw	hp	m3/h	m			GPM 88	141	211	282	352	423	493	564	634	705				
			l/min 333	533	800	1067			1333	1600	1867	2133	2400	2667	m ³ /h 20	32	48	64	80	96	112	128
H=Head/Altura/Hauteur(m)																						
FSP-4	650	100	1.5	2	40	3	76	1.5	3.8	3.3	2.6	-	-	-	-	-	-	-	-	-	-	
	750	100	1.5	2	45	4	76	2.4	-	4.5	3.7	3	-	-	-	-	-	-	-	-	-	
	850	100	2.2	3	53	5	76	4.9	-	6	5.3	4.5	3.5	-	-	-	-	-	-	-	-	
	950	100	3	4	60	6	76	5.8	-	7.5	6.5	5.7	5	-	-	-	-	-	-	-	-	
	1050	100	5.5	7.5	65	7.5	76	6.7	-	9.7	8.7	7.8	6.8	5.9	-	-	-	-	-	-	-	-
	1150	100	5.5	7.5	72	9	76	7.3	-	11.9	10.8	9.9	8.8	7.6	-	-	-	-	-	-	-	-
	1250	100	7.5	10	80	10.5	76	7.6	-	14.2	13.2	12	10.8	9.5	8.4	-	-	-	-	-	-	-
	1350	100	11	15	85	12.5	76	7.6	-	16.7	15.7	14.3	13.1	11.8	10.5	-	-	-	-	-	-	-
	1450	100	11	15	100	13.5	76	7.6	-	-	18	16.5	15.5	14	12.5	11.5	-	-	-	-	-	-
	1550	100	15	20	110	15.5	76	7.6	-	-	20.9	19.8	18.3	16.9	15.4	13.8	12.6	-	-	-	-	-
	1650	100	18.5	25	115	18	76	7.6	-	-	24.3	22.9	21.1	19.8	18.1	16.3	15	-	-	-	-	-
	1750	100	22	30	120	20	76	7.6	-	-	27.6	26.2	24.4	22.9	21.3	19.3	17.5	16.2	-	-	-	-
1850	100	30	40	130	22.5	76	7.6	-	-	31	29.8	27.7	26.1	24.4	22.5	20.5	18.7	-	-	-	-	
1950	100	30	40	135	25	76	7.6	-	-	34.5	33.4	31.5	29.4	27.7	25.7	23.5	21.7	-	-	-	-	

MODEL MODELO MODÈLE	RPM	DN mm	Power Potencia Puissance		Rate Q/H		Max Solids Sólido máx Max solide	Max Suction Succión máx Asp. max	Q=DELIVERY/CAUDAL/DÉBIT													
			kw	hp	m3/h	m			GPM 220	352	441	529	661	793	925	1057	1189	1322				
			l/min 833	1333	1667	2000			2500	3000	3500	4000	4500	5000	m ³ /h 50	80	100	120	150	180	210	240
H=Head/Altura/Hauteur(m)																						
FSP-6	650	150	3	4	100	3.5	76	2.4	5	4.2	3.7	3.1	-	-	-	-	-	-	-	-	-	
	750	150	4	5.5	125	4.5	76	2.7	-	6	5.5	4.7	3.6	-	-	-	-	-	-	-	-	
	850	150	7.5	10	150	5.5	76	3.6	-	8	7.3	7	5.5	-	-	-	-	-	-	-	-	
	950	150	7.5	10	160	7.5	76	4.2	-	11	9.8	9.5	7.5	6.8	-	-	-	-	-	-	-	
	1050	150	11	15	180	9	76	5.5	-	13	12	11	10	9	7.5	-	-	-	-	-	-	
	1150	150	15	20	200	10	76	6.4	-	16	15	14	12.8	11.2	10	8	-	-	-	-	-	-
	1250	150	22	30	220	12.5	76	6.4	-	-	18	17	15.5	14	12.7	10.5	-	-	-	-	-	-
	1350	150	30	40	230	15	76	6.7	-	-	21.5	20.5	19	17.5	15.5	14	12	-	-	-	-	-
	1450	150	30	40	250	17	76	7	-	-	24.5	24	22	21	19	17	15	13	-	-	-	-
	1550	150	37	50	280	18	76	7.6	-	-	-	28	26	24.5	22.7	20.5	18.5	16.5	-	-	-	-

MODEL MODELO MODÈLE	RPM	DN mm	Power Potencia Puissance		Rate Q/H		Max Solids Sólido máx Max solide	Max Suction Succión máx Asp. max	Q=DELIVERY/CAUDAL/DÉBIT												
			kw	hp	m3/h	m			GPM 440	661	881	1101	1322	1542	1762	1982	2203	2555			
			l/min 1667	2500	3333	4167			5000	5833	6667	7500	8333	9667	m ³ /h 100	150	200	250	300	350	400
H=Head/Altura/Hauteur(m)																					
FSP-8	650	200	7.5	10	200	6	76	2.7	7	6.5	6	5	-	-	-	-	-	-	-	-	-
	750	200	11	15	230	8	76	3.7	-	8.8	8.5	7.5	6.5	-	-	-	-	-	-	-	-
	850	200	15	20	260	10	76	4.6	-	11.5	11	10	9	8	-	-	-	-	-	-	-
	950	200	22	30	300	12	76	5.2	-	15	14	13	12	11	-	-	-	-	-	-	-
	1050	200	30	40	320	15	76	6.1	-	18.5	17.5	16.5	15.5	14	13	-	-	-	-	-	-
	1150	200	37	50	350	18	76	6.4	-	-	21.5	20.3	19	18	16.5	15.5	-	-	-	-	-
	1250	200	55	75	400	20	76	6.7	-	-	25.5	24.5	23	22	20	19	18	-	-	-	-
	1350	200	75	100	450	23	76	7	-	-	30.5	29	27.8	26	25	23	22	-	-	-	-
1450	200	75	100	500	26	76	7	-	-	35.5	34	32	31	30	28	26	23	-	-	-	-

TECHNICAL DATA/DATOS TÉCNICOS/DONNÉES TECHNIQUES

MODEL MODELO MODÈLE	RPM	DN mm	Power Potencia Puissance		Rate Q/H		Max Solids	Max Suction	Q=DELIVERY/CAUDAL/DÉBIT													
			kw	hp	m3/h	m			GPM 881	1322	1762	1982	2203	2423	2643	2863	3084	3304				
			l/min 3333	5000	6667	7500			8333	9167	10000	10833	11667	12500	m ³ /h 200	300	400	450	500	550	600	650
H=Head/Altura/Hauteur(m)																						
FSP-10	650	250	11	15	250	6.5	76	2.1	7	6.5	-	-	-	-	-	-	-	-	-	-	-	
	750	250	15	20	300	8.5	76	3.4	10	8.5	6	-	-	-	-	-	-	-	-	-	-	
	850	250	22	30	350	11	76	4.3	13	11.5	10	8	-	-	-	-	-	-	-	-	-	
	950	250	30	40	400	13	76	5.2	16	15	13	12	10	-	-	-	-	-	-	-	-	
	1050	250	45	60	450	16	76	5.5	20	19	17	16	14.5	12.5	-	-	-	-	-	-	-	
	1150	250	55	75	500	19	76	5.5	-	23	21	20	19	17.5	15	-	-	-	-	-	-	-
	1250	250	75	100	525	23	76	5.8	-	27.5	25.5	24.5	23.5	22	20.5	18	-	-	-	-	-	-
	1350	250	90	125	550	27	76	6.7	-	32.5	30.5	29.5	28	27	25.5	23.5	21.5	-	-	-	-	-
	1450	250	90	125	600	31	76	6.7	-	38	38	35	33.5	32	31	29.5	27.5	24.5	-	-	-	-

MATERIAL DESCRIPTION/DESCRIPCIÓN DE MATERIAL/DESCRIPTION DU MATÉRIEL

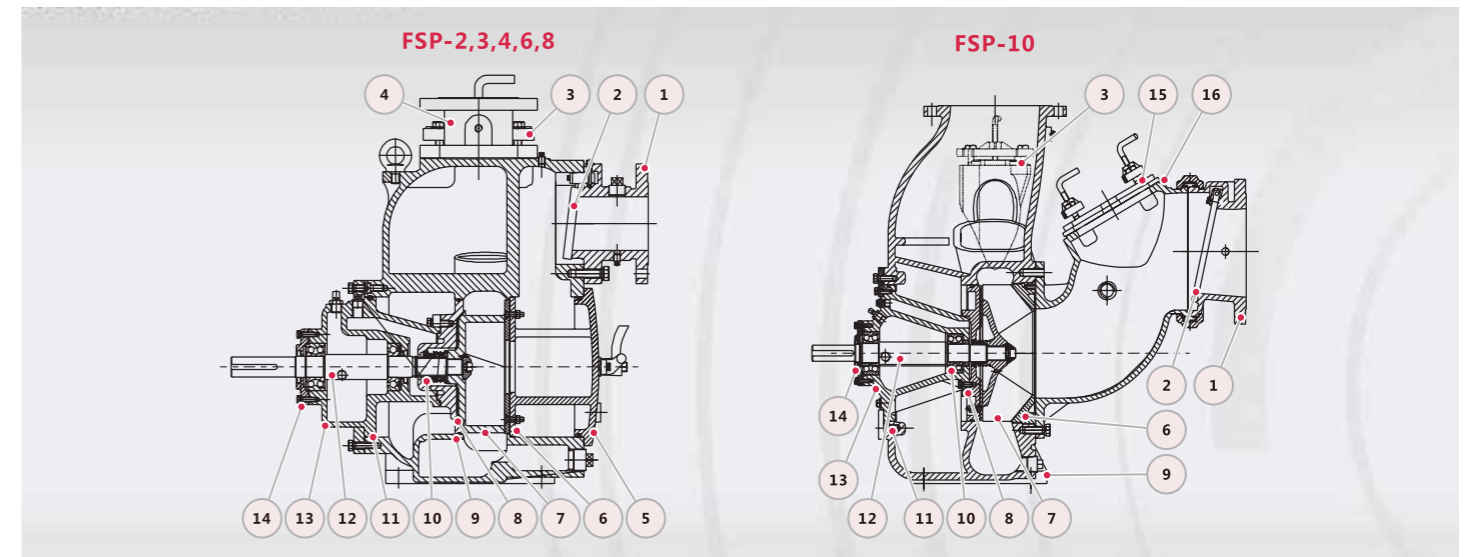

No.	Description Descripción Description	Material Material Matériel
1	Suction inlet Entrada succión Entrée d'aspiration	Cast iron Fundición Fonte
2	Check valve Válvula retención Clapet anti-retour	Rubber Caucho Caoutchouc
3	Infusion cover Cubierta de infusión Couverture de perfusion	Cast iron Fundición Fonte
4	Discharge outlet Salida de descarga Sortie de décharge	Cast iron Fundición Fonte
5	End cover tapa final Couvercle	Cast iron Fundición Fonte
6	Wear plate Placa de desgaste Plaque d'usure	Carbon Steel Acero al Carbono Acier Carbone
7	Impeller Impulsor Roue	Cast iron Fundición Fonte
8	Impeller cover Cubierta impulsor Couvercle de roue	Cast iron Fundición Fonte

No.	Description Descripción Description	Material Material Matériel
9	Volute Voluta Volute	Cast iron Fundición Fonte
10	Mechanical Seal Cierre Mecánico Garniture mécanique	WC/WC/SS304 WC/WC/Inox304 WC/WC/Inox304
11	O-Ring Junta tórica Joint torique	Rubber Caucho Caoutchouc
12	Shaft Eje Arbre	SS304 Inox 304 Inox 304
13	Bearing body Cuerpo rodamiento Corps roulement	Cast iron Fundición Fonte
14	Bearing cover Tapa cojinete Couvercle palier	Cast iron Fundición Fonte
15	Inlet cover Tapa entrada Couvercle d'entrée	Cast iron Fundición Fonte
16	Inlet Entrada Entrée	Cast iron Fundición Fonte

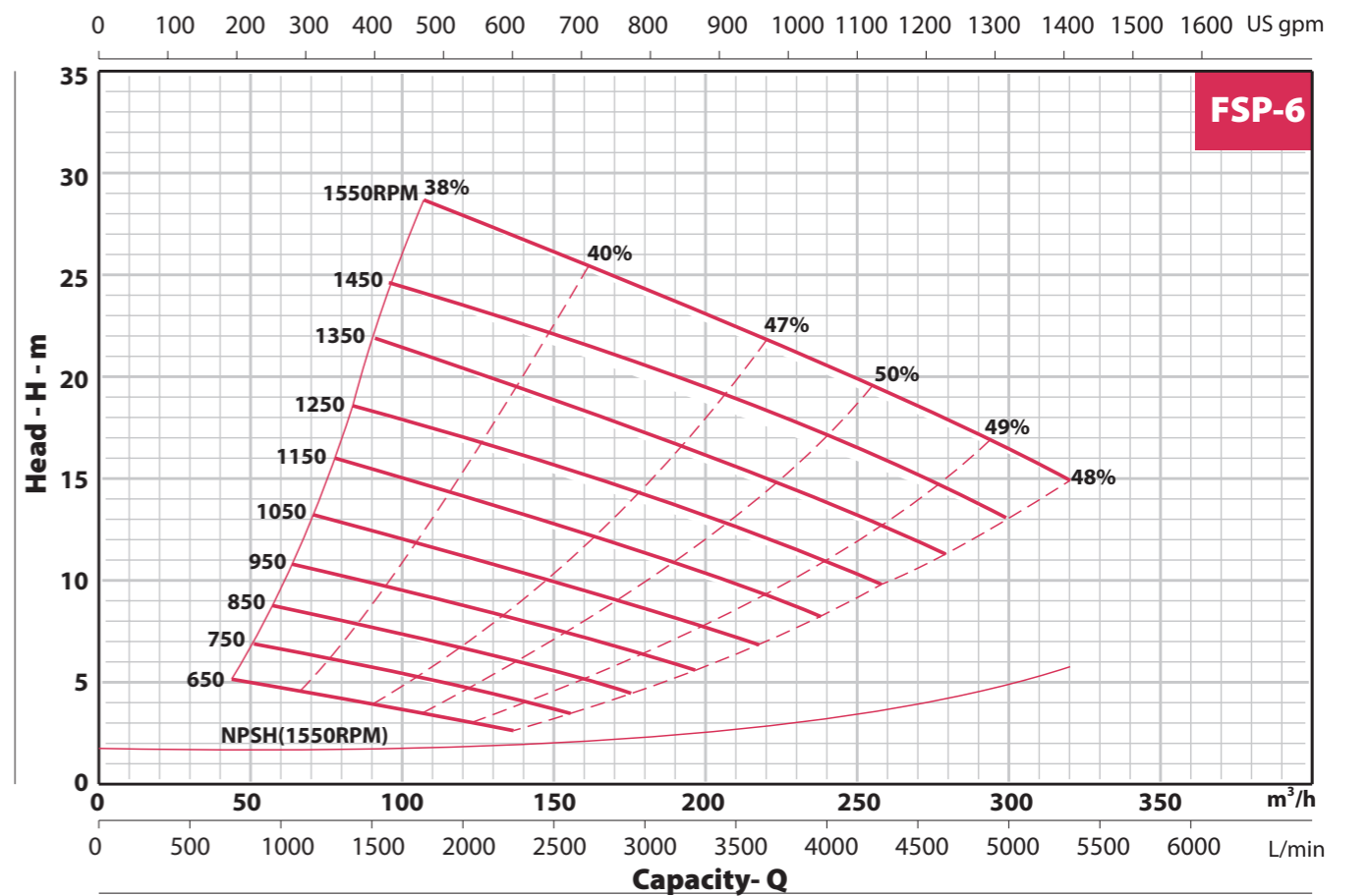
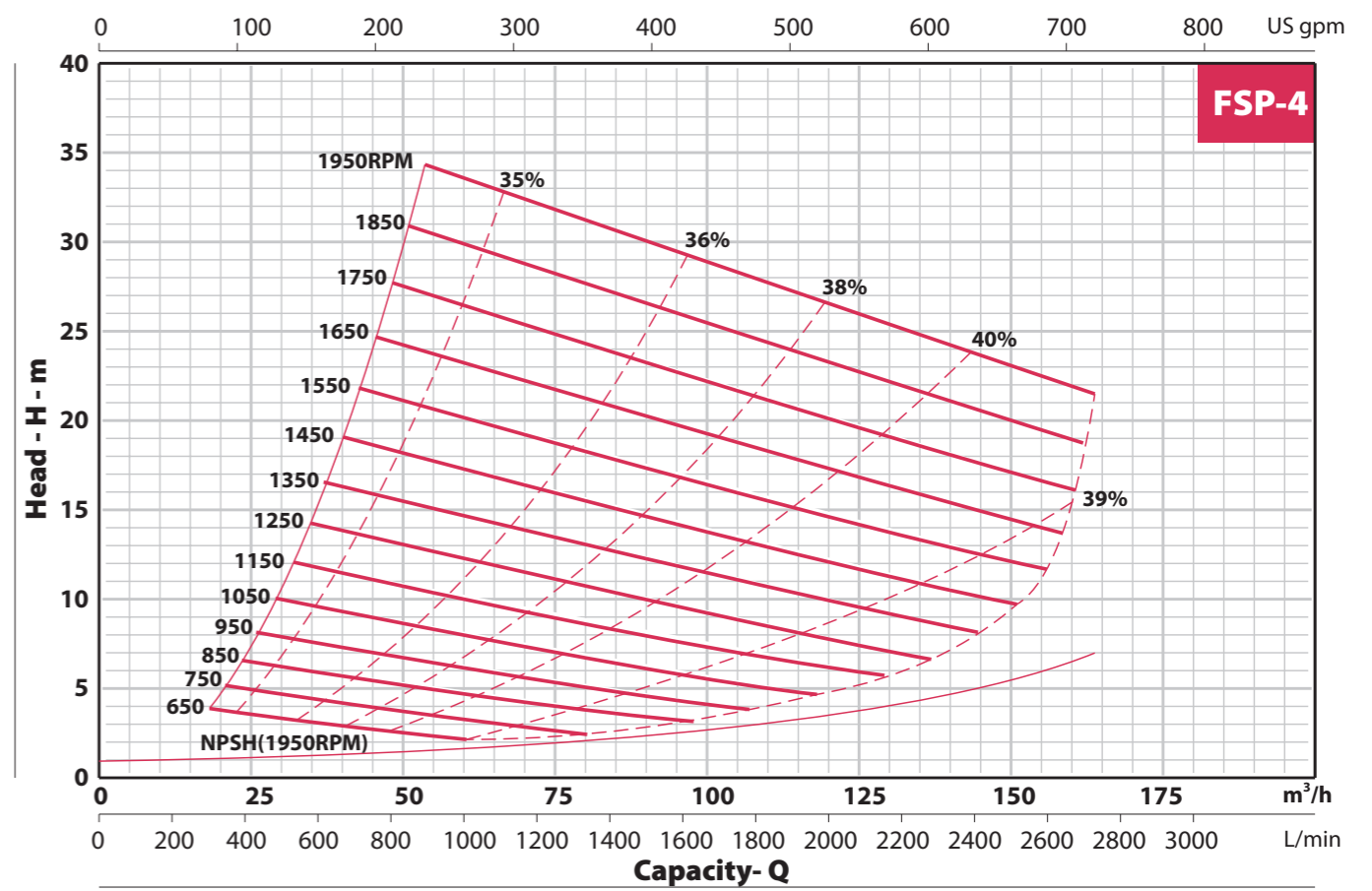
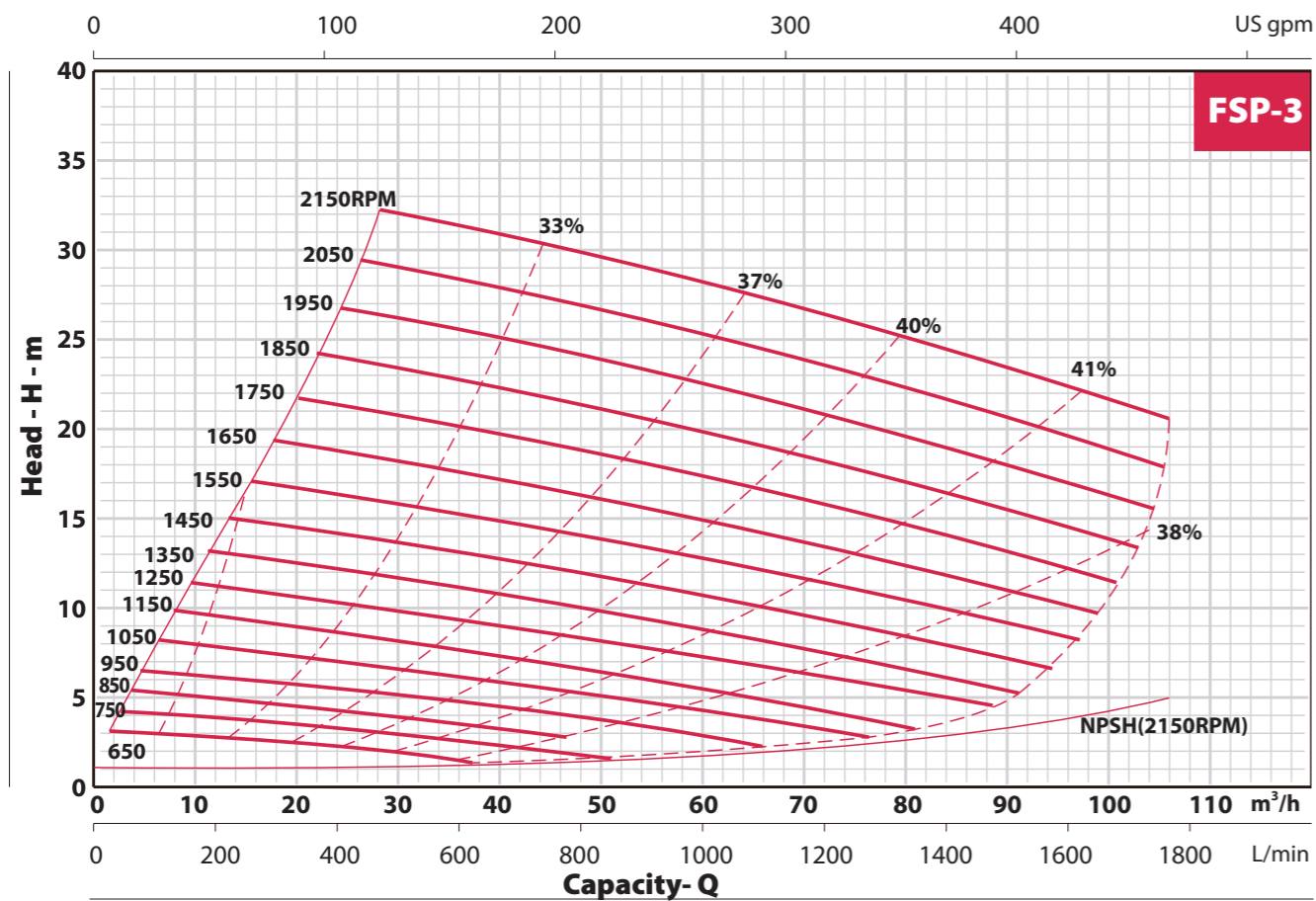
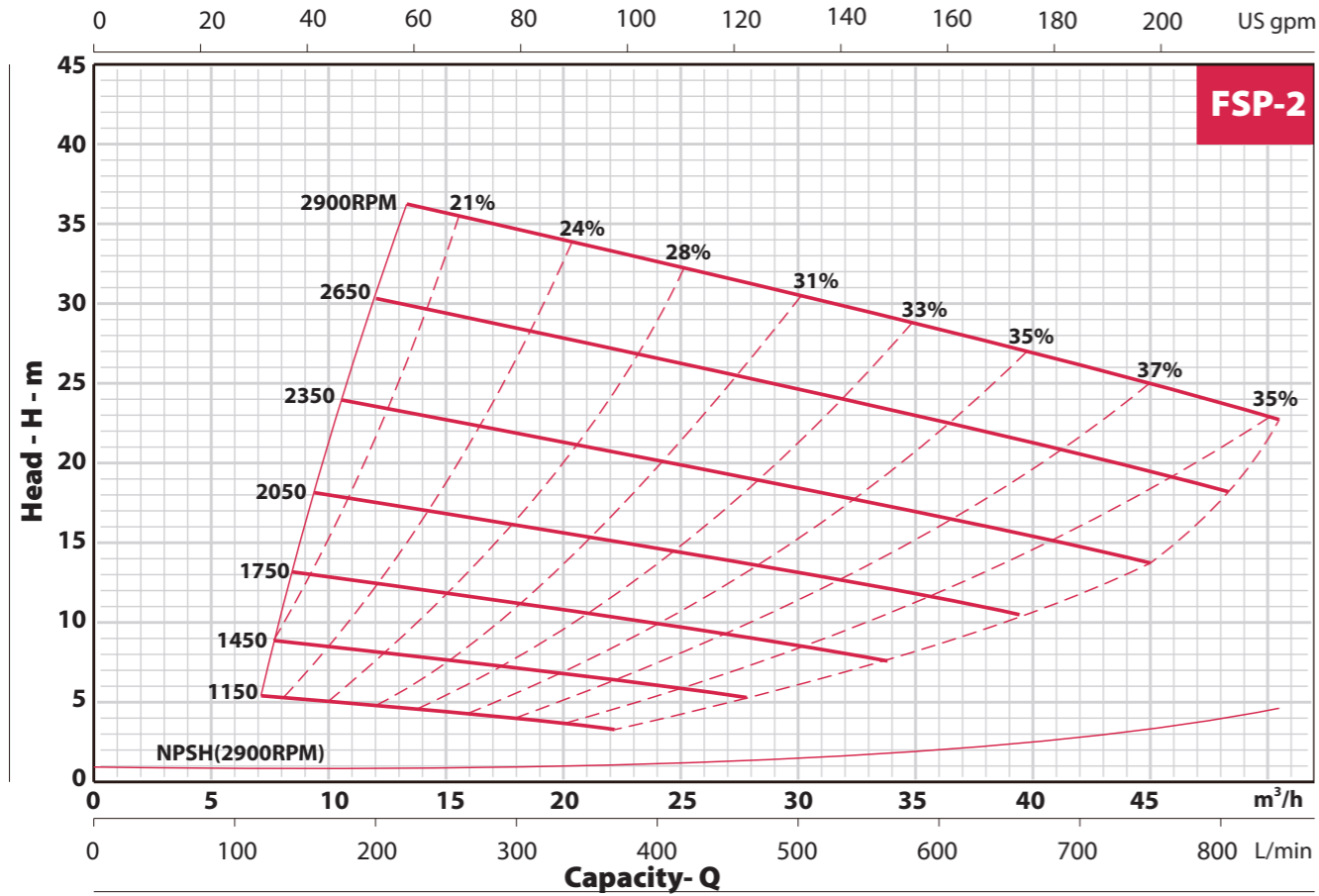

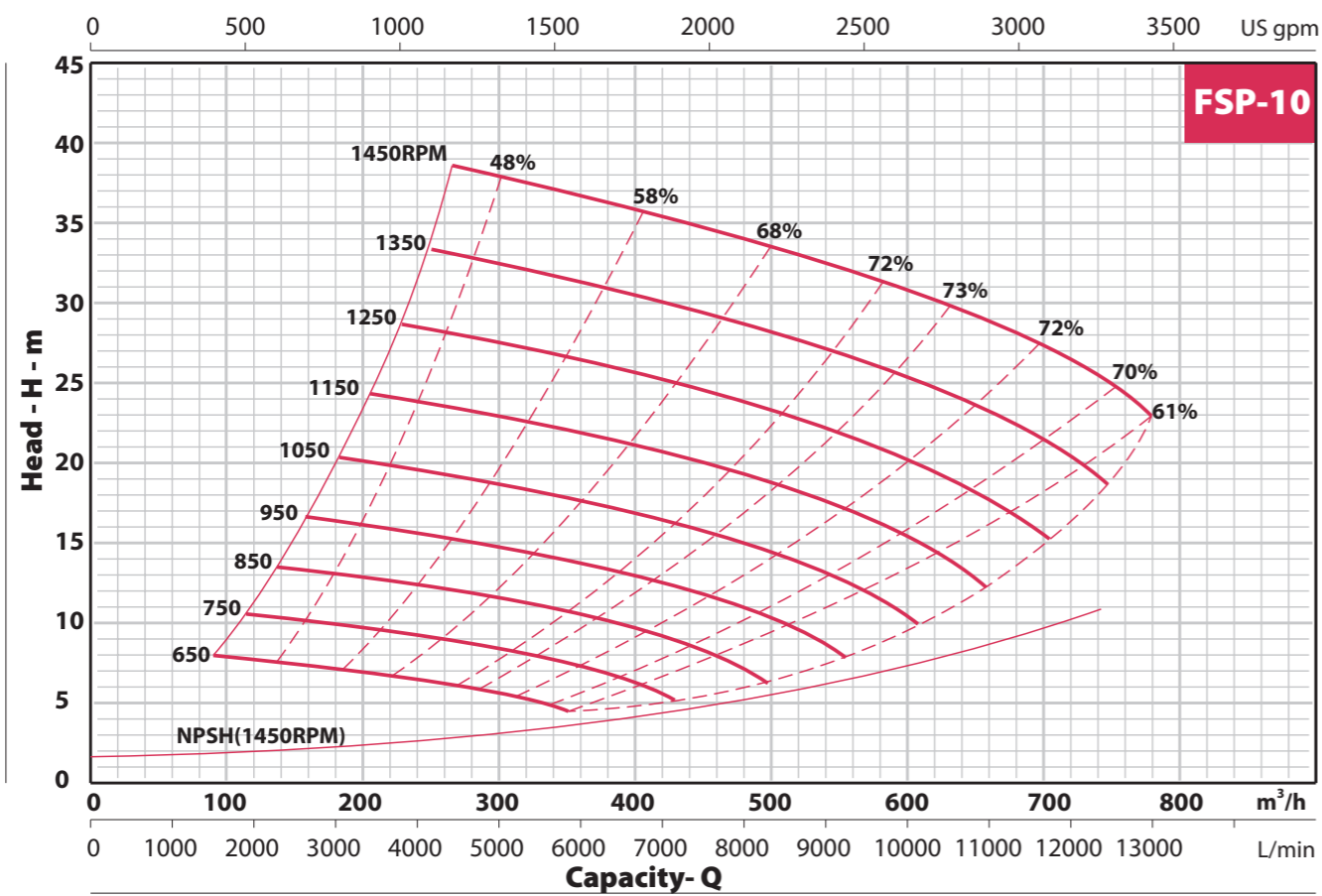
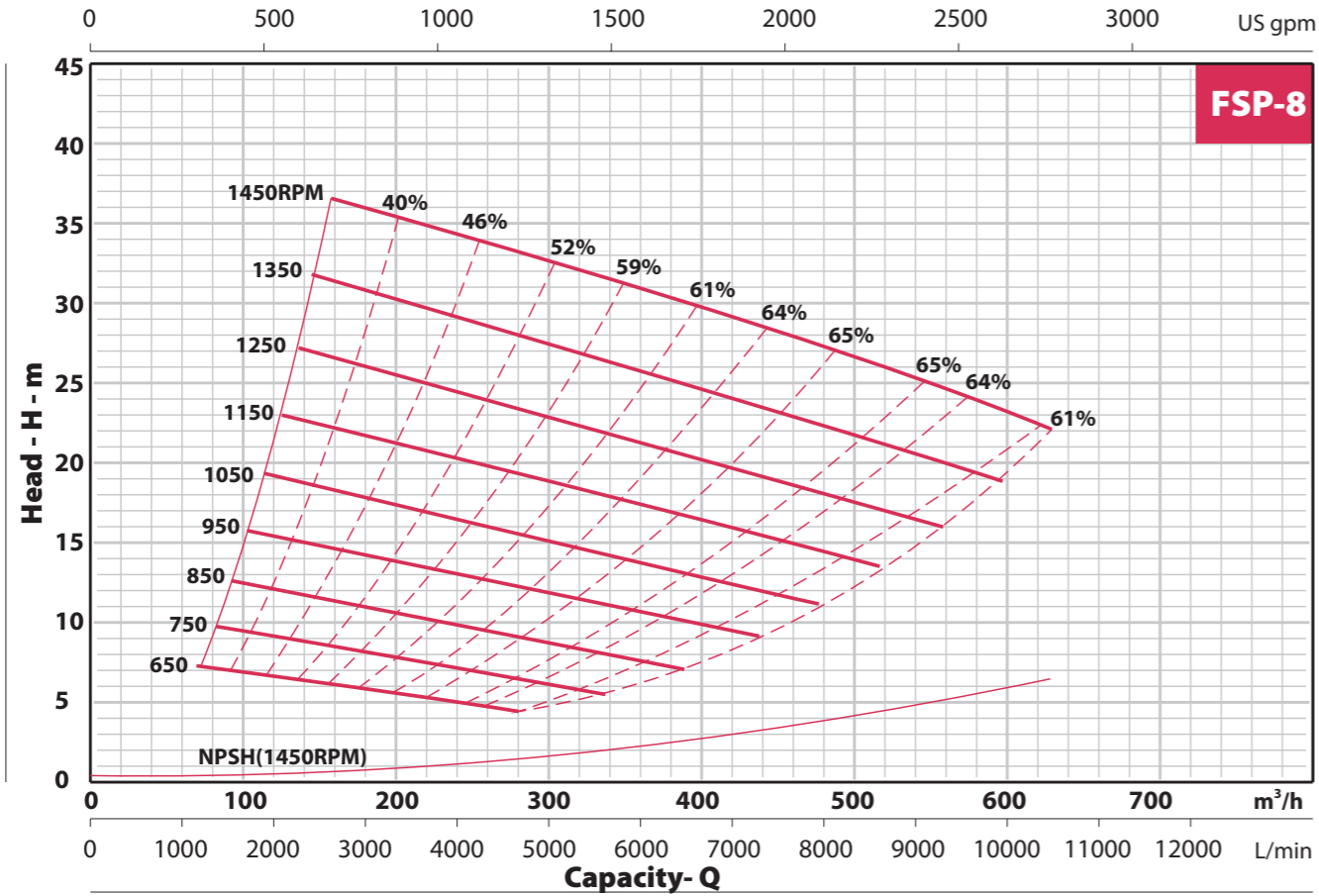

DIMENSIONS AND WEIGHT/DIMENSIONES Y PESOS/DIMENSIONS ET POIDS

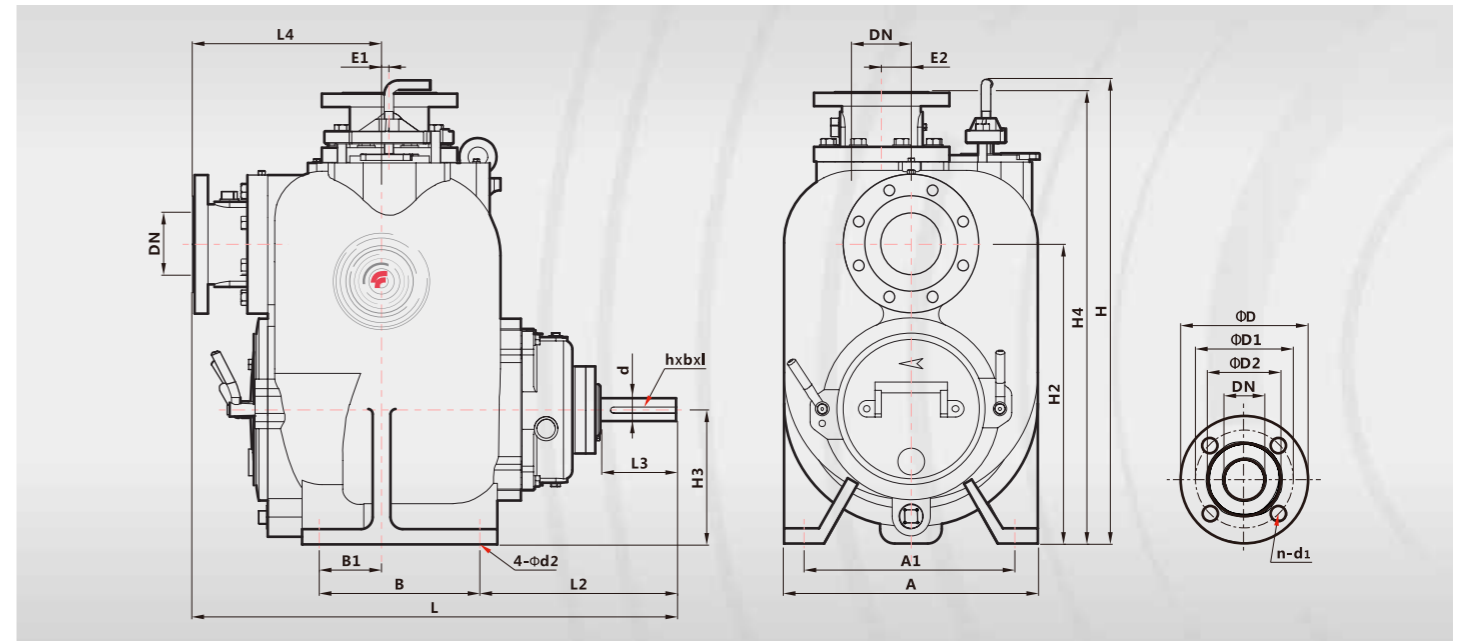

Item	FSP-2	FSP-3	FSP-4	FSP-6	FSP-8	FSP-10	
Flange Dimension Brida Dimension Bride Dimension Dimension (mm)	PN	0.6MPa	0.6MPa	1.0MPa	1.0MPa	1.6MPa	
	DN	50	80	100	150	250	
	D	140	190	228.6	285	340	405
	D1	110	150	180	240	295	355
	D2	90	127	158	212	266	320
	n-d1	4-14	4-19	8-19	8-23	8-23	12-26
	hxbxl	10x5x95	10x5x80	10x5x90	10x5x95	14x3.5x127	14x3.5x120
Installation Dimension Instalación Dimension Installation Dimension Dimension (mm)	H2	318	431.8	495.3	574.3	723.8	639.8
	A	308	377	428	580	716	705
	A1	281	328	373	527	635	635
	B	163.2	228.6	279.4	279.4	304.8	304.8
	B1	54	76.2	110	77.8	101.6	101.6
	L2	274.8	285	326	294	407.1	320.6
	d2	14	18	18	18	24	24
	H3	151.5	190.5	222.2	257.2	330.2	355.6
	L3	104	102	127	127	170	123
	d	38	38	38	38	48	48
Profile Dimension Perfil Dimension Dimension (mm)	H	552	697.5	760	875	989	1017
	Amax	321	389	429	580	716	786
	H4	502	652	735	887.7	1069.3	1047.8
	L	615	712.2	813.5	906.6	1023	1244.7
	L4	233	277	318	411	412.8	720.9
	E1	27.5	15	13	0	0	0
	E2	70	50	50	50	0	0
N.W/kg	99	190	275	438	655	705	